



Measures Technology Values Innovation



## VRLA Rechargeable Battery

# HRC9-12 (HRC9-12FR)

### FEATURES

- Maintenance free(no water topping-up required)
- No free acid(Non-spillable battery)
- Can be used in any orientation(excluding used inverted)
- The battery is designed for high rate usage
- Its design life is up to 5 years in floating application
- Absorbent Glass Mat technology for efficient gas recombination
- The power density at 5 min~15min discharging rate is 30% higher than BP series

### APPLICATION

- UPS
- Laboratory Equipment
- Fishing Lights
- Fishing Lights Booster
- Power Packs
- Toy-Cars



### SPECIFICATIONS

Nominal Voltage	12V	
Nominal Capacity	10 Hour Rate (800mA, 10.5V)	8.0 Ah
	15 Min Rate (216W, 7.8V)	4.5 Ah
Approx. Weight	2550g(5.62lbs.)	
Terminals	T2 (Faston Tab 250) , T1 and B0 are optional	
Max. Discharge Current	120 A (5 sec.)	
Max. Charge Current	2.4 A	
Operating Temperature Range	Charge	0°C~40°C(32°F~104°F)
	Discharge	-20°C~50°C(-4°F~122°F)
	Storage	-20°C~40°C(-4°F~104°F)
Self Discharge	< 3% per month (25°C)	
Internal Resistance	≤ 15mΩ (Fully Charged )	

### CONTAINER MATERIAL

- HRC9-12:  
ABS: 94-HB (Dark gray color)
- HRC9-12FR:  
ABS: 94-V0 (Light gray color)

ISO 9001

ISO 14001

ISO 14001

CE

C4M20310-2474-E-16

- IEC61056
- JIS C 8702
- GB/T 19639

OUTER DIMENSIONS mm(Inch)	Length (L)	Width (W)	Container Height (H)	Total Height (TH)
	151±1.5(5.94±0.06)	65±1.5(2.56±0.06)	94±1.5(3.70±0.06)	100±2.0(3.94±0.08)

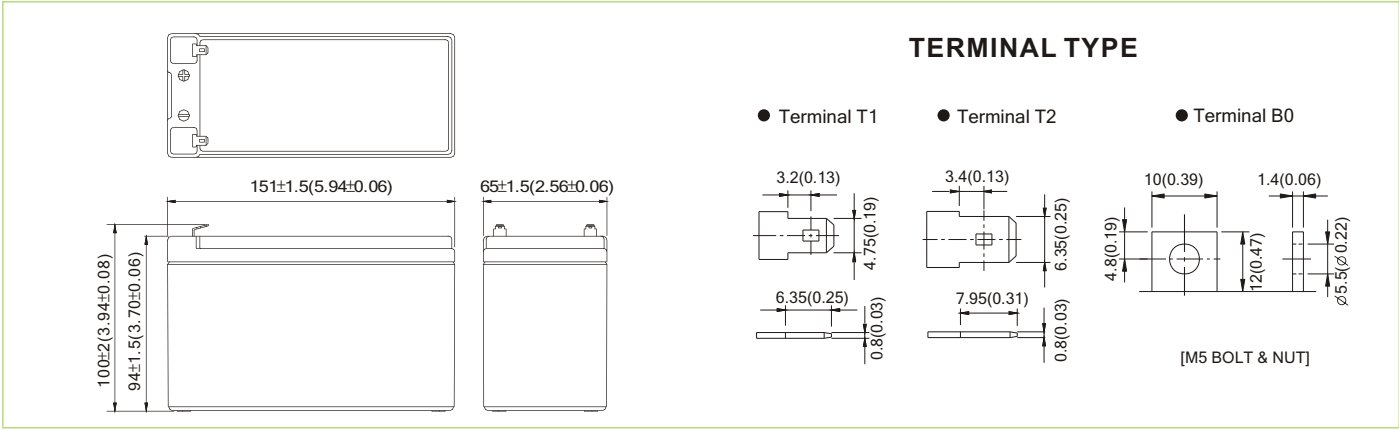

### HRC9-12 (HRC9-12FR) discharge characteristics (25°C/77°F)

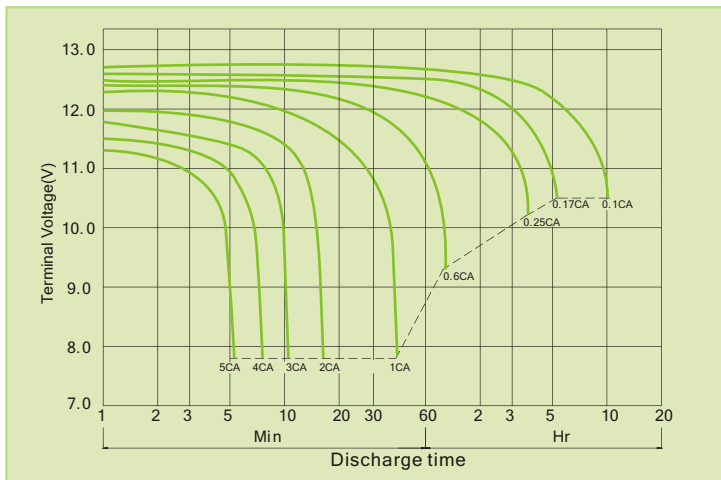

### Battery Charging Characteristics

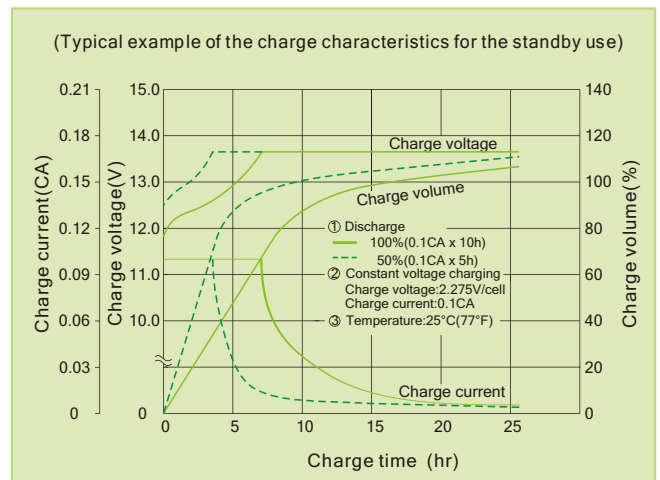

### Charging Procedure

Application	Charging method	Charging Voltage at 25°C (V/cell)	Temperature compensation coefficient of charging voltage (mV/°C/cell)	Max. charging current (CA)	Charging time 0.1CA, 25°C (h)		Temp (°C)
					100% discharge	50% discharge	
For standby power Source	Constant voltage & Constant current charging (with current restriction)	2.25~2.30	-3	0.3	24	20	0~40 (32~104°F)
For cycle service					16	10	

### Effect Of Temperature On Long Term Float Life

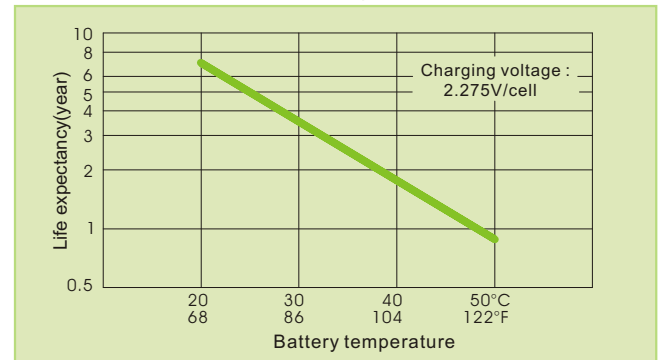

### Constant power discharge characteristics at 25°C/77°F Unit: W

F.V. (V/cell) \ Discharge Time	5 Min	10 Min	15 Min	20 Min	30 Min	40 Min	50 Min	60 Min	120 Min
1.80V	369.0	252.0	182.5	155.7	118.4	90.0	75.2	66.2	36.5
1.70V	441.0	281.3	198.5	164.9	123.3	93.4	77.6	67.7	37.2
1.60V	472.5	295.9	207.5	171.0	126.0	95.6	79.2	68.9	37.8
1.50V	486.0	301.5	212.0	173.7	127.6	96.8	80.1	69.5	38.0
1.40V	495.0	305.6	214.4	175.3	128.5	97.4	80.8	70.0	38.1
1.30V	499.5	308.3	216.0	176.4	129.2	97.9	81.2	70.2	38.2

### Constant current discharge characteristics at 25°C/77°F Unit: A

F.V. (V/cell) \ Discharge Time	5 Min	10 Min	15 Min	20 Min	30 Min	40 Min	50 Min	60 Min	120 Min
1.80V	32.95	22.11	15.79	13.35	10.03	7.57	6.29	5.52	3.04
1.70V	40.09	24.68	17.17	14.14	10.45	7.86	6.49	5.64	3.10
1.60V	42.95	25.96	17.95	14.67	10.68	8.04	6.63	5.74	3.15
1.50V	44.18	26.45	18.34	14.90	10.81	8.14	6.70	5.79	3.17
1.40V	45.00	26.81	18.55	15.03	10.89	8.19	6.76	5.83	3.18
1.30V	45.41	27.04	18.69	15.13	10.95	8.23	6.79	5.85	3.18

All data shall be changed without prior notice, BB reserves the right to explain and update the information contained hereinto.

Trial A/2 REV. Feb. 2011

**USA:**  
B&B BATTERY(USA) INC.  
6415 RANDOLPH ST.COMMERCE,CA,90040 U.S.A.  
TEL:1-323-278-1900.1-800-278-8599  
FAX:1-323-278-1268  
E-Mail:sales@bb-battery.com

**CHINA FACTORY:**  
B.B. BATTERY CO., LTD.  
CHENG DONG TRIAL AREA,HUANG GANG,  
RAOPING, GUANG DONG,CHINA,515700  
TEL:86-768-7601001-2  
FAX:86-768-7601469  
E-Mail:maggy@bb-battery.com

**EUROPE:**  
B&B BATTERY(EUROPE) B.V.  
SUITE 8, HAAKSBERGWEG 33, 1101  
BP AMSTERDAM, THE NETHERLANDS  
TEL: 31-30-3200190  
MOBILE: 886-933896989  
E-Mail: gary@bb-battery.com

**HONG KONG:**  
B&B BATTERY(Hong Kong) Co.  
TEL:852-2311-4918  
FAX:852-2739-1182  
E-Mail:bbhk@hkstar.com

**JAPAN:**  
B&B BATTERY(JAPAN) CO., LTD.  
1375-11 NARAHARA-MACHI,HACHIOJI,  
TOKYO 193-0803,JAPAN.  
TEL:81-426-25-6375  
FAX:81-426-25-6375  
E-Mail:miyata@bb-battery.com

**TAIWAN:**  
B.B. BATTERY(TAIWAN) CO., LTD.  
TEL:886-6-502-5150  
FAX:886-6-589-8087  
E-Mail:kevin@bb-battery.com

Web Site: <http://www.bb-battery.com>

Powered by **B.B. Battery Co., Ltd.**